

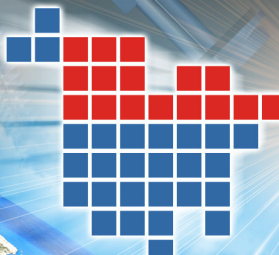

**North-American
Manufacturer of
Fasteners for OEM
and distribution**



100%
**NORTH AMERICAN
MADE**



STANDARD AND CUSTOM FASTENERS ENGINEERED TO YOUR SPECIFICATIONS

Leland Industries Inc. (founded in 1984) and joined by Canadian Threadall Limited in 2014.

“Canadian Threadall Limited” began operating in 1982 in Waterloo, Ontario. From the start CTL staff rapidly earned a solid reputation for their expertise in manufacturing quality threaded products in most ferrous and non-ferrous metals, engineered to customers’ specifications.

Today, companies across Canada and the United States call CTL for customized threading, bending, concrete forming hardware, anchor bolts, threaded rod, u-bolts, j-bolts, and eye-bolts.

Canadian Threadall Limited, and it’s employees bring a wealth of technical experience to the Leland Group. We, at Leland welcome their enthusiasm and dedication to “quality control”, continuing employee education through in-house training, and commitment to providing their many customers “consistent quality”.

In September 2017, CTL began operating out of our newly purchased 50,000 square foot facility in Cambridge, Ontario. We look forward to offering our many customers expanded capabilities in manufacturing and the ability to serve diverse market opportunities.

From the beginning, Leland Industries concentrated on domestic manufacture of bolts, nuts, and screws for the agricultural storage and metal building segments of North America’s construction industry. Growth came quickly. Two bolt making machines and six employees evolved into a two hundred strong manufacturing force, operating over 300 pieces of equipment in Leland’s own 205,000 square foot plant, warehouse, and head office facility.

The purchase of additional bolt makers has expanded our bolt making capability to a maximum ¾” x 6”. This, when combined with “Canadian Threadall” capabilities, brings Leland Industries the design expertise, engineering capabilities, and manufacturing capacity to produce almost any specialty fastener required.

See below for a complete listing of Leland and Canadian Threadall Manufacturing’s capabilities.

Leland Capabilities:

- Heading
- Thread Rolling
- Trimming
- Slot Forming
- Point Forging
- Shank Slotting
- Assembly
- Electrostatic Powder Painting
- Custom Packaging
- Salt Spray Testing
- Nut Forming
- Nut Tapping
- Wire Drawing

Canadian Threadall Capabilities:

We have the capacity to thread and form parts as small as #4-40 and as large as 4½” in diameter. We can manufacture special threaded rods and studs, and provide a full range of coarse, fine, and acme threads up to 4½” in diameter – in both right and left hand styles, including ACME.

- Manufacturing for the automotive, mining, construction, and retail markets
- Engineering innovative ideas to better your product
- Threading up to 4½” cut and rolled thread. Thread milling to 16”
- Threaded rods in stock up to 3” diameter in all grades of material
- Bent and formed parts to 4” including “U”, “EYE”, “J”, and “L”
- Taper ties and concrete forming accessories
- Anchor bolts and threaded rod
- Forged bolts and special parts
- Custom CNC machining and milling



Quality:

All Leland and Canadian Threadall products are produced to rigorous benchmarks of quality that surpass the test of today’s exacting needs of engineering. Whether those items are based on international standards or customers demands.

All Leland products are traceable to each stage of manufacturing. We are accredited by A2LA* to ISO/IEC 17025 for Mechanical Testing, Certification Number: 1053.01. Please review our scope of accreditation at: www.lelandindustries.com.

*A2LA Accreditation applies to Leland manufactured products only.

100% North America



Head Office: (416) 291-5308

JS1000

**GUARANTEED PERFORMANCE THAT
OUTPERFORMS PREMIUM COATINGS
At A FRACTION OF THE COST.**

Years of research and experience in the manufacture of long-life fasteners have produced a true innovation: The Leland JS1000® extreme life plating.

The proof is in the testing:

The incredible JS1000® has been proven to remain completely rust-free in over 1000 hours of salt spray testing. That's a phenomenal 20 – 25 times the corrosion resistance of regular electro-zinc products – and considerably more than the best known coatings on the market.

JS1000® delivers the kind of performance you've only been able to get by making the costly jump to stainless steel. At a price that is far more cost effective. The only product today that could offer superior rust resistance would be 300 Series stainless steel.

Check out the features of Leland's JS1000®:

- Reduced tapping torque and less stress on small diameter fasteners!
- Totally compatible with aluminum and other metals used in construction!
- Hexavalent Chromium Free and R.O.H.S compliant – environmentally friendly!

Suitability of the products described herein, for the purpose intended, is the sole responsibility of the design engineer, architect or otherwise responsible person charged with the design of the structure.

Rely on North American quality!

JS1000® is an exclusive Leland formula

JS1000® is applied to all Leland and CTL products as required

JS1000® is 100% North American

**LONG LIFE
WARRANTY!**

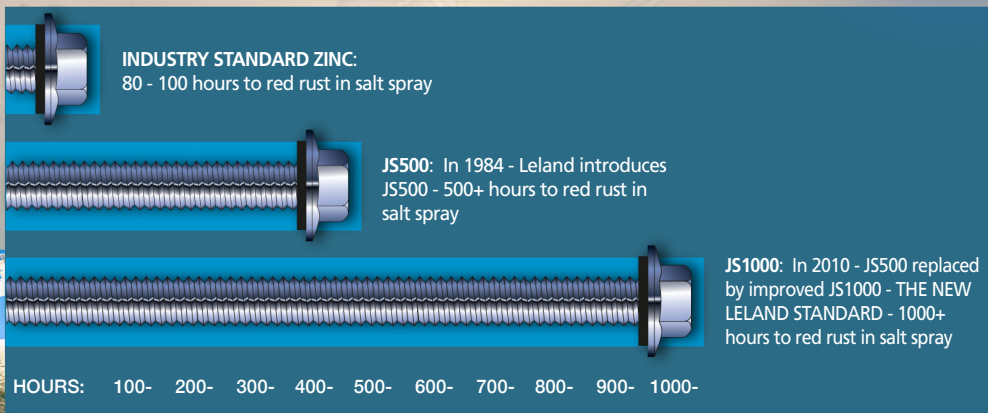
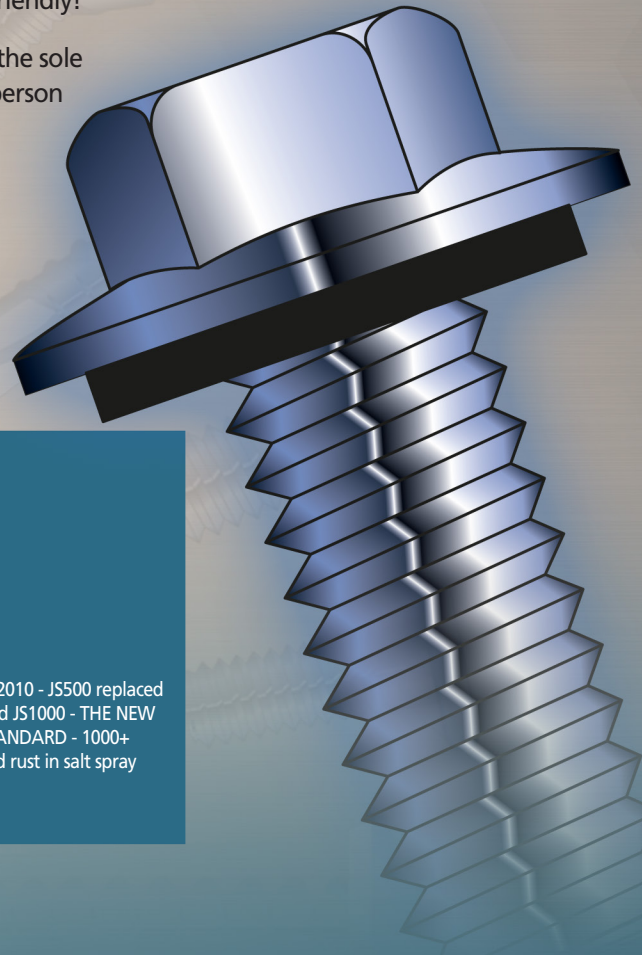

American Made

LELAND BOLTS FOR METAL CONSTRUCTION

SERRATED FLANGE LOCKING BOLTS

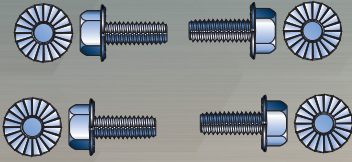

SERRATED FLANGE BOLTS & NUTS

ROUND HEAD & PAN HEAD FIN NECK LOCKING BOLTS



INSTALLATION OF METAL DOORS & WINDOW FRAMES

A325 STRUCTURAL BOLTS

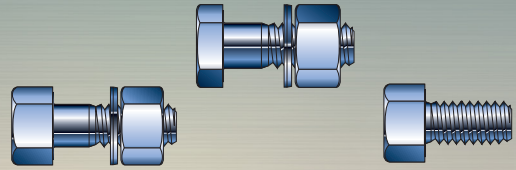

1/2" TO 3/4" DIAMETER FOR ALL STRUCTURAL FRAME ASSEMBLIES TO 6" LENGTH - FULLY THREADED

CULVERT & GUARD RAIL FASTENERS

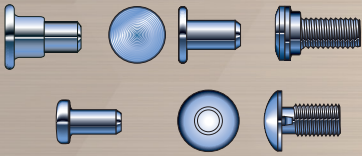

SOLID RIVETS & VARIOUS BOLTS & NUTS FOR HIGHWAY & DRAINAGE INDUSTRIES

STANDARD NUTS, BOLTS, SCREWS

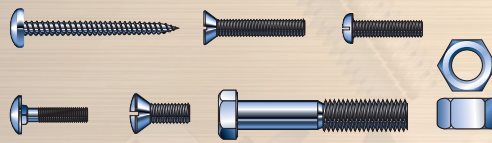

GRADES 2 - 5 - 8 - CAP SCREWS - CARRIAGE BOLTS - LAG BOLTS - NUTS - MACHINE SCREWS - ETC.

TANK BOLTS

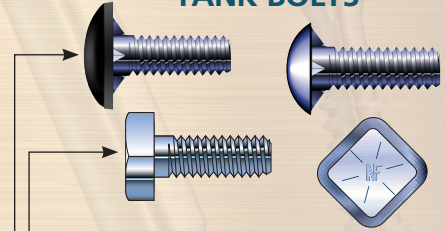

- INDENTED SQUARE HEAD CHIME BOLT
- ENCAPSULATED HEAD TANK BOLT

HEAVY HEX STRUCTURAL BOLT ACCESSORIES

NEW GIRT SAFETY SPACER NUT

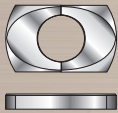

RECOMMENDED FASTENER TO MEET OSHA 51926.758 SYSTEMS - ENGINEERED METAL BUILDINGS

SQUIRTER® DTI WASHERS

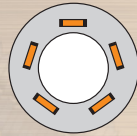

NOW YOU CAN SEE THAT THE BOLT IS TIGHT

SHOWS **ORANGE** WHEN TIGHT
Squirter® DTI's & Squirter® DTI are registered trademarks of Applied Bolting Technology Products Inc.

NEW BRACER™ HILLSIDE STYLE WASHERS

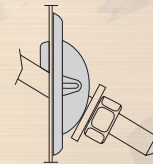

ANCHORS X-BRACING FOR METAL BUILDINGS

NEW Expanded bolt offering to 3/4" x 6"

- Headed Bolts to 3/4" x 6"
- Plow Bolts
- Fin Neck Bolts
- Encapsulated Bolts
- Harrow Bolts
- A325 Structural Bolts
- Serrated Shelving Bolts
- Carriage Bolts
- Elevator Bolts
- Clevis Pins
- Culvert Bolts
- Serrated Flange Locking Bolts, GR. 2, 5, 8
- Machine Screws
- Purlin & Girt Bolts
- Square Head Bolts

Grade 2, 5, 8, 300 Series and 410 Stainless Steel Available

Call for a quote!

SPECIAL BOLTS

PLOW BOLTS & CULTIVATOR BOLTS

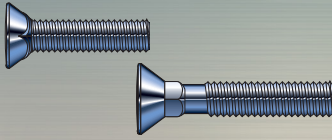

SHAKER SCREEN BOLTS

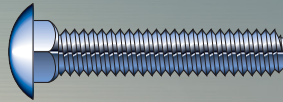

KNURLED NECK BOLT

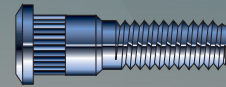

ELEVATOR BOLT

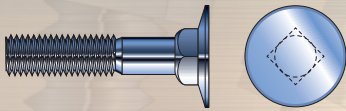

WHEEL BOLTS & STUDS

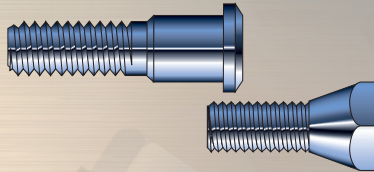

RIBBED & SMOOTH NECK CARRIAGE BOLTS

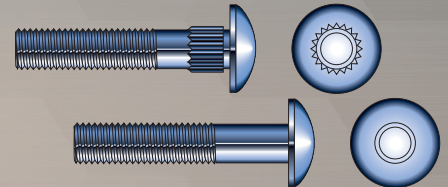

CLOSET BOLTS



HIGH HEAD HARROW BOLTS

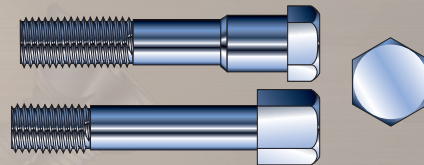

All products are available in carbon or stainless steel, inch or metric dimensions.

CLEVIS PINS

STYLE "A"



STYLE "B"

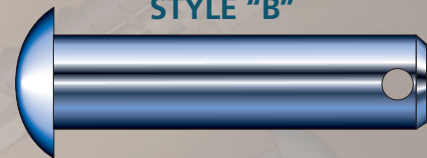

WE MAKE NUTS!



**FINISHED
HEX NUTS**



**HEAVY
HEX NUTS**



**PLAIN
FLANGE
NUTS**



**SERRATED
FLANGE
NUTS**



**REGULAR
& HEAVY
SQUARE NUTS**



**HEX NUTS
SERRATED
BOTH SIDES**



**WHEEL
NUTS
90° CONE**



**WHEEL
NUTS
60° CONE**

Nuts are available in carbon steel, 304 and 316 stainless steel

American Made



Demand Leland "NF" & "L" head markings that guarantee 100% North American manufactured fasteners made with North American Steel

All product is manufactured by Leland Industries and is available in metric dimensions



LELAND SPECIALTY FASTENERS

MASTER GRIPPERS®

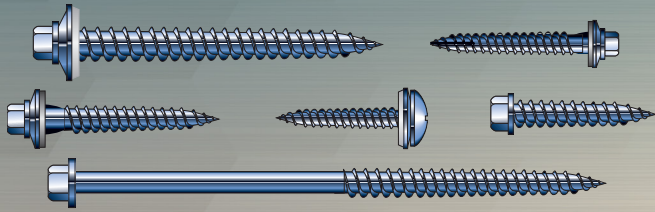

FOR THE POST FRAME BUILDING INDUSTRY
LONG LENGTHS TO 8" AVAILABLE

MASTER GRIPPERS MDP®

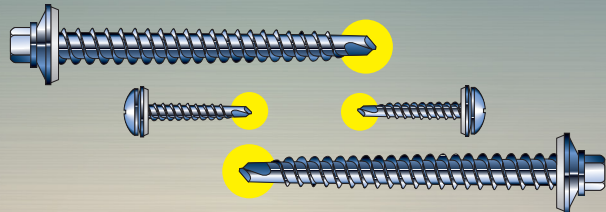

METAL PANEL TO WOOD OR LIGHT STEEL GIRT
OR PURLIN

MASTER ONE STEPPERS®

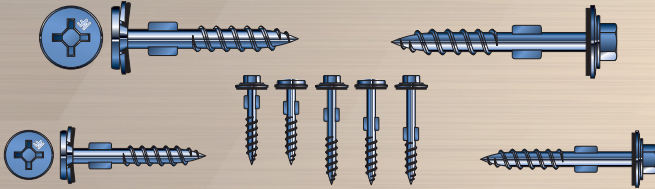

PVC, FRP PANELS TO WOOD - REAMER WINGS
PROVIDE CLEARANCE IN PANELS TO ALLOW
THERMAL EXPANSION

MASTER DRILLERS®

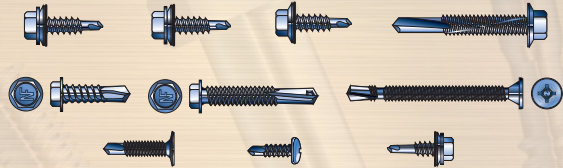

ATTACH METAL PANEL TO METAL GIRT OR PURLIN,
STITCHING & STRUCTURAL APPLICATIONS
LENGTHS TO 8" AVAILABLE 1/4-14 & 1/4-20, SD3, SD5

MASTER TAPPERS®

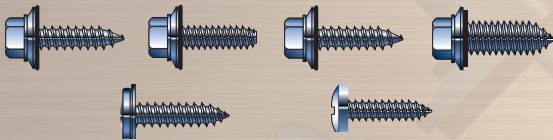

ROOF PANEL TO PANEL - ROOF SHEET TO STRUCTURAL
A - AB - B POINTS AVAILABLE, TYPE F, TYPE 23 & MORE
LONG LENGTHS TO 8" AVAILABLE

GUTTER SCREWS

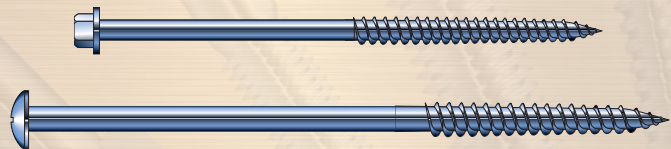

LENGTHS TO 8"
AVAILABLE

WAFER PLYMETAL SELF DRILL

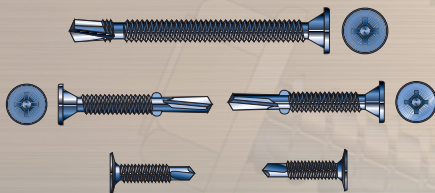

PLYWOOD TO METAL

LOW PROFILE PANCAKE HEADS



CONCEALED FASTENERS FOR
METAL ROOF CLIPS TO STEEL
OR WOOD PURLINS

MASTER DECKERS®

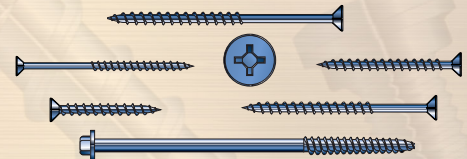

ACQ COMPATIBLE DECKING SCREWS
LENGTHS TO 6" AVAILABLE
CARBON STEEL & STAINLESS

OVERHEAD GARAGE DOOR FASTENERS

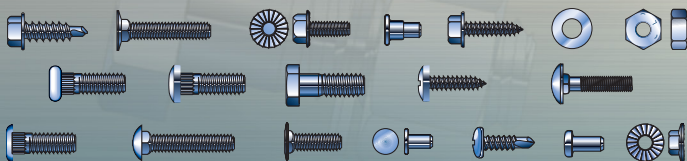

FULL RANGE OF FASTENERS & BOLTS FOR
RESIDENTIAL, COMMERCIAL & INDUSTRIAL DOORS
KIT PACKAGING AVAILABLE

SCREWS

SHEET METAL SCREWS

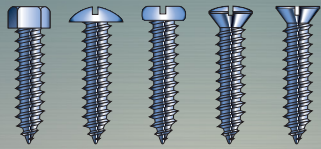

HEX TRUSS PAN OVAL FLAT

MACHINE SCREWS

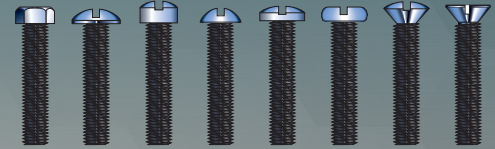

HEX TRUSS FILLISTER ROUND BINDING PAN OVAL FLAT

THREAD TYPES



25 BG BF 23 G F 1 17 C BP AB B A

WOOD SCREWS

Cut their own mating thread in wood. In hard wood, a pre-drilled starter hole is required to prevent splitting of the material.



PAN FLAT ROUND OVAL

LAG SCREWS

Fasteners with threaded conical point, normally used in wood or masonry with an expansion anchor fitted to a pre-drilled hole.



SQUARE HEAD LAG SCREW HEX HEAD LAG SCREW

DRIVING RECESSES

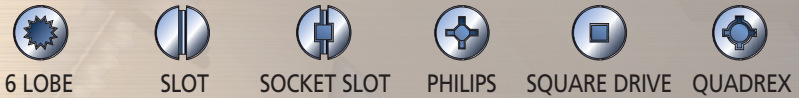

6 LOBE SLOT SOCKET SLOT PHILIPS SQUARE DRIVE QUADREX

FLASHINGS & ACCESSORIES AVAILABLE FROM LELAND INDUSTRIES INC.

MASTER FLASH®

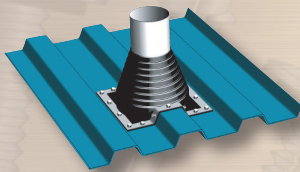

UNIVERSAL PIPE FLASHING SYSTEM NOW AVAILABLE IN POPULAR COLORS ROUND & SQUARE BASE AVAILABLE

SQUARE VENT MASTER FLASH®



SPECIALLY DESIGNED FOR SQUARE VENT APPLICATIONS

EXTREME ANGLE MASTER FLASH®

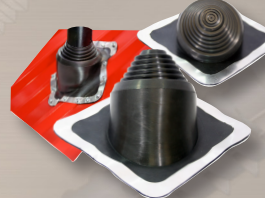

FOR APPLICATIONS WITH A 35 TO 65 DEGREE ANGLE

RETROFIT MASTER FLASH®

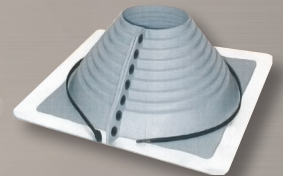

EASILY INSTALLED FASTENER SNAPS INCLUDED

VERSATILE DEKSTRIP® EXPANDABLE-EDGE FLASHING & DEK-CAP®

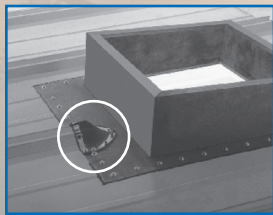

THE ONLY UNIVERSAL STANDING SEAM ROOF END CAP FLASHING

UNIVERSAL ROUND BASE MASTER FLASH®

RETROFIT ALSO AVAILABLE



FAST, EASY ON-SITE INSTALL

MULTI-FLASH MASTER FLASH®



TWO FLASHINGS IN ONE

SOLAR MASTER FLASH®



SPECIALLY DESIGNED FOR SOLAR APPLICATIONS

RESIDENTIAL MASTER FLASH®

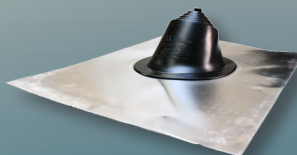

"ALUMINUM BASE", FOR USE WITH ASPHALT SHINGLE ROOFING. ENVIRONMENTALLY SAFE.

MASTER SURFACE DRIVE BITS™

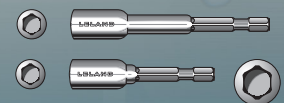

MAGNETIC SURFACE DRIVE BITS WITH LOBULAR SOCKET



QUADREX & SQUARE DRIVE BITS

American Made

Master Closure are registered trademarks of Aztec Washer Co.

www.leland.ca

COATING SYSTEMS

ALL LELAND AND CANADIAN THREADALL FASTENERS ARE PRODUCED WITH HEXAVALENT CHROMIUM-FREE PLATINGS. (Limited to Leland's exclusive JS, DT and NZF platings)

OTHER COATINGS AVAILABLE:

Phosphate & Oil, Hot Dip Galvanizing

Leland fasteners are also available in 410 Stainless & 300 Series materials.

JS1000[®] PLATING SYSTEM

JS1000 PLATING SYSTEM IS AN ENHANCED ANTI-CORROSION PROTECTION SYSTEM THAT IS APPLIED TO ALL FASTENERS MANUFACTURED BY LELAND AND CANADIAN THREADALL

JS1000 PLATING SYSTEM IS APPLIED BEFORE ANY ADDITIONAL COATING
1000 HOURS SALT SPRAY LIFE, 3 TO 5 CYCLES, 2 LITRE SO₂/CYCLE KESTERNICH.
IN THE EVENT OF A SCRATCH, JS REACTS WITH ZINC TO SEAL THE SCRATCH.

NZF3000[®] SERIES LONGLIFE SYSTEM

**THE ULTIMATE CORROSION PROTECTION SYSTEM
NO RISK OF HYDROGEN EMBRITTLEMENT
INORGANIC ZINC RICH CORROSION PROTECTION BASE COAT
CONTAINING ZINC AND ALUMINUM FLAKES**

PROVIDES UP TO 3,000 HOURS OF RUST-FREE PERFORMANCE IN SALT-SPRAY TESTS
5 TIMES MORE THAN HOT DIP GALVANIZING
60 TIMES MORE THAN ELECTRO-PLATED PRODUCT

DT[®]1700 LONGLIFE SYSTEM

**DT1700 LONGLIFE COATING IS A SPECIAL ANTI-CORROSION PROTECTION SYSTEM
ACQ COMPATIBLE FOR TREATED WOOD**

DT1700 LONGLIFE COATING IS APPLIED OVER A
SUBSTRATE OF JS1000.

JS600 PLATING SYSTEM

**JS600 PLATING SYSTEM IS A
HIGH LUBRICITY ANTI-CORROSION
PROTECTION SYSTEM FOR STAINLESS STEEL**

LELAND'S JS600 PLATING SYSTEM ELIMINATES
GALLING DURING ASSEMBLY.



**POWDER COATED TOUGH IS THE NEW STANDARD
IN PAINTED FINISHES**

**LELAND POWDER COATS UNDER THE FASTENER HEAD WHERE CORROSION BEGINS.
ABSOLUTELY THE FINEST, MOST DURABLE, PROTECTIVE COATING IN THE
FASTENER INDUSTRY**

POWDER PAINT OVER JS1000 EXCEEDS
3000 HOURS SALT SPRAY LIFE AND EXCEEDS
50 CYCLES, 2L SO₂/CYCLE
KESTERNICH.

100% North America

PACKAGING PROGRAMS



RETAIL RACK PROGRAM
CHOICE OF 27" or 36" RACKS

DISPLAY BOXES OF HANDY BAGGED FASTENERS



CUSTOM JOB PACKS
ALL FASTENER AND ACCESSORIES INDIVIDUALLY PACKED IN QUANTITIES TO SUIT BILL OF MATERIAL REQUIREMENT & LABELLED WITH JOB NUMBER

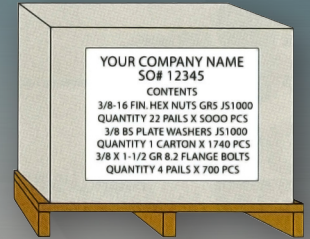

HEAVY DUTY CORRUGATED 1/4 KEG CARTONS
BULK PACKED

SQUARE PLASTIC PAILS
BULK PACKED IN PLASTIC BAGS
WATERPROOF - TAMPER PROOF & RE-SEALABLE
HAS A SECURITY STRIP TO INDICATE PAIL HAS BEEN OPENED



ROUND PLASTIC PAILS
BULK PACKED WATERPROOF & RE-SEALABLE

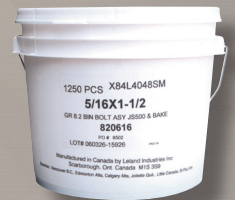

CLAM SHELL CONTAINERS
VARIOUS SIZES AVAILABLE ON CUSTOM ORDERS OR PRIVATE LABEL PROGRAMS



PLASTIC BAG PACKAGING
VARIOUS SIZES AVAILABLE ON CUSTOM ORDERS OR PRIVATE LABEL PROGRAMS

LELAND INDUSTRIES USES ONLY PALLETS AND PACKAGING PRODUCED OR REPAIRED TO ISPM15 STANDARDS TO PREVENT THE SPREAD OF WOOD PESTS



American Made

NOW LELAND OFFERS CUSTOM THREADING CAPABILITY

With the acquisition of Canadian Threadall Limited., Canada's largest custom threader, Leland can offer you a complete variety of quality threaded products in most ferrous and non-ferrous metals.

We have the capability to thread and form parts as small as #4-40 and as large as 4-1/2 inches in diameter. We can manufacture special threaded rods and studs, and provide a full range of coarse, fine and acme threads up to 4-1/2" in diameter – in both right and left hand styles, including ACME.

- Manufacturing for the automotive, mining, construction and retail markets
- Engineering innovative ideas to better your product
- Reverse engineered products from broken or failed samples
- Threading up to 4-1/2" cut and rolled thread. Thread milling to 16"
- Threaded rods in stock up to 3" diameter in all grades of material
- Bent and formed parts to 4" including "U", "EYE", "J" and "L"
- Taper ties and concrete forming accessories
- Anchor bolts and threaded rod
- Forged bolts and special parts
- Custom CNC machining and milling



**CANADIAN
THREADALL
LIMITED**

**STANDARD & CUSTOM FASTENERS
ENGINEERED TO YOUR SPECIFICATIONS**

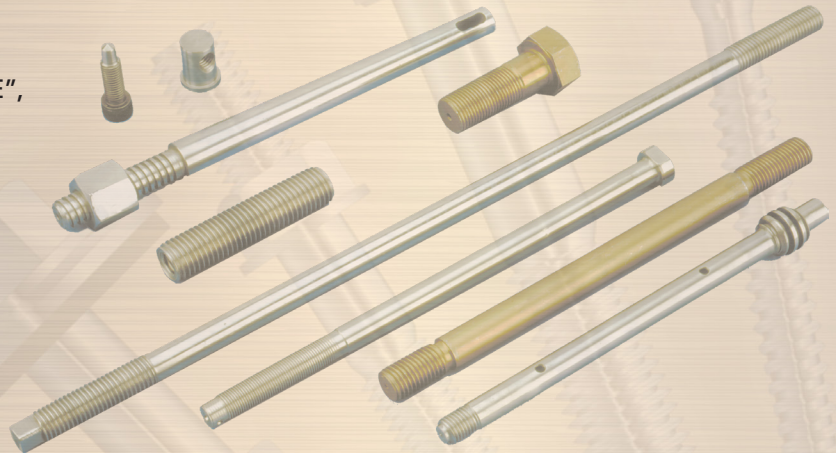

ISO 9001

Excellence Since
1982

BENT BOLTS

U-BOLT, ROUND BEND



U-BOLT, SQUARE BEND

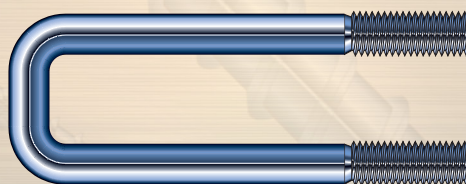

EYE BOLT, OPEN



**HOOK BOLT,
SPECIAL**

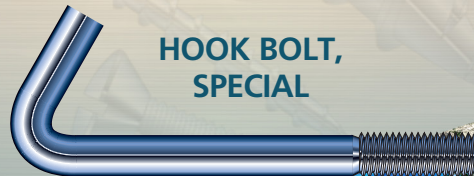

J-BOLT

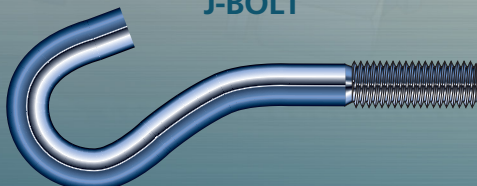

**ANCHOR
BOLT**



100% North American

CUSTOMIZED ORDERS

Custom threading is one of the company's specialties, but the ability to supply a variety of products is an important priority at CTL. We have the capability to manufacture special threaded rods and studs and to provide a full range of coarse, fine and Acme threads up to four inches in diameter in both right and left hand threads.

Aside from its manufacturing capability, CTL stocks a full inventory of threaded rods, nuts, washers and miscellaneous fasteners.

CTL's bending equipment includes a 4" Bull Bender, which is able to bend a variety of configurations. In addition to this, a group of hydraulic benders exists that can form a host of shapes and sizes such as "Eye Bolts", "U-bolts", "J-bolts" and "L-bolts". Materials can be bent from 1/16 of an inch to 4 inches in diameter.

- Cut and Roll Thread in Imperial, Metric and Specials
- Thread Milling to 16" (400mm)
- Hot Forging up to 1 1/8"
- CNC Milling and Turning
- Secondary Operations Drilling, Tapping, Slotting

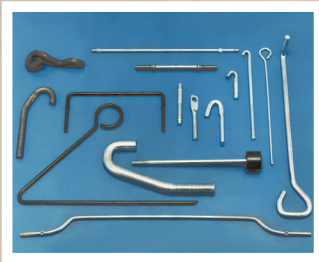

Bent Wire Forms



Threaded Rod

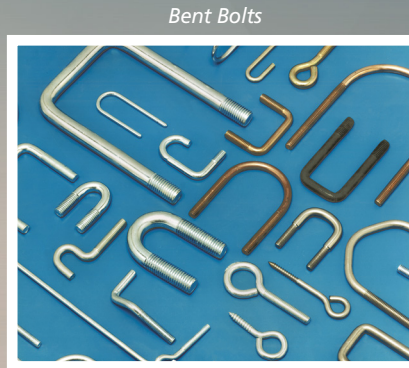

Bent Bolts

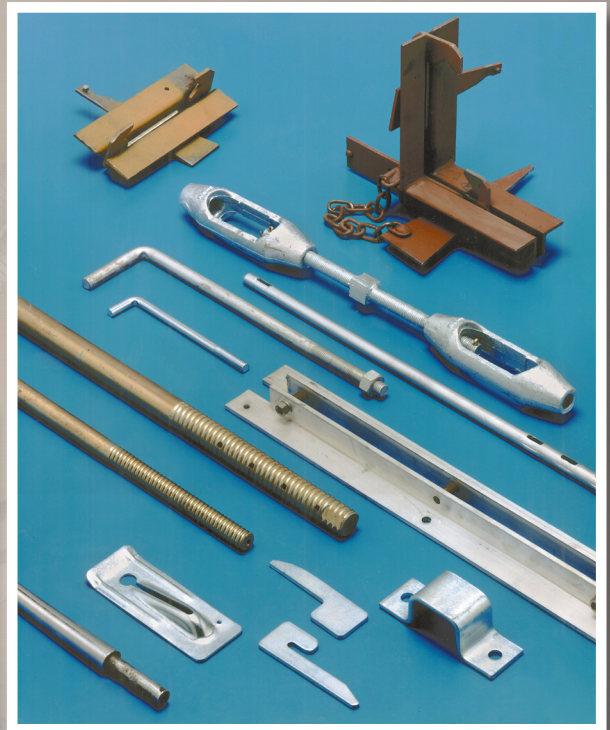

Concrete Accessories

Grade 2, 5, 5.2, 8, Stainless Steel & Alloy Available

Call for a quote!

- Formed Eye Bolts
- Threaded Rod
- ACME Threaded Parts
- J-Bolts
- Eye Bolts
- U-Bolts, #6 wire to 4"
- Anchor Bolts

American Made



LELAND
LAND

EQUIPMENT

- ACCREDITED TESTING LAB
- ASSEMBLY
- BOLT MAKERS
- HEADING
- NUT FORMING
- NUT TAPPING
- POINTING
- POWDER COATING
- SHANK SLOTTING
- THREAD ROLLING
- TOOL ROOM
- TRIMMING



TESTING LABORATORY

ACCREDITATION TO ISO / IEC – 17025

SCOPE: MECHANICAL CERTIFICATION NUMBER: 1053.01

THERE ARE INTERNATIONAL AGREEMENTS OF MUTUAL RECOGNITION WITH EUROPE,
THE AMERICAS AND PACIFIC RIM COUNTRIES

The ISO/IEC 17025 accreditation applies to mechanical testing and does not imply certification/approval of the products described.

See the lab scope on our website for the specific tests covered by the accreditation.

This accreditation is restricted to the quality assurance laboratory located at the manufacturing plant and head office in Toronto, Ontario, Canada.



HEAD OFFICE (416) 291-5308 • FAX (416) 291-0305 • 95 COMMANDER BOULEVARD, TORONTO, ON, M1S 3S9, CANADA

FOR CANADIAN THREADALL:

(519) 576-3360 • TOLL FREE: 1-877-777-2612 • FAX (519) 576-3991 • 130 TURNBULL COURT, CAMBRIDGE, ON, N1T 1J2, CANADA • www.threadall.com

BRANCHES

BC, Port Coquitlam (604) 472-1041, Fax (604) 472-1051
 ALBERTA, Calgary (403) 252-4414, Fax (403) 259-8876
 ALBERTA, Edmonton (780) 453-2766, Fax (780) 455-8261
 QUEBEC, Joliette (450) 756-1441, Fax (450) 756-1678

KANSAS, Shawnee
 MINNESOTA, Maplewood
 OKLAHOMA, Tulsa

(888) 292-6166, Fax (888) 292-6228
 (651) 483-9990, (800) 388-3043, Fax (651) 484-2778
 (918) 949-4023, (844) 260-2438, Fax (918) 949-4024

1-800-263-3393, North America Wide

www.lelandindustries.com